



# Food Processor Food Processor/Cutter Mixer 5.8 QT - Variable Speed

ITEM # \_\_\_\_\_  
 MODEL # \_\_\_\_\_  
 NAME # \_\_\_\_\_  
 SIS # \_\_\_\_\_  
 AIA # \_\_\_\_\_



600578 (DK55VVU)

Food Processor/Cutter Mixer  
5.8 qt stainless steel bowl  
with clear BPA-free lid,  
equipped with scraper.  
Variable speed (300-3700  
RPM)

## Short Form Specification

### Item No.

Food Processor/ Cutter Mixer, bench-style, variable speed (300-3700 RPM), removable bowl, stainless steel bowl with clear BPA-free lid, microtooth blade rotor, stainless steel housing, 300-3700 RPM.

WARRANTY: 1 year Parts and 1 year Labor

## Main Features

- Emulsifier function (scraper) included as standard.
- Base fixed cover for a better handling.
- All parts in contact with food are removable without the use of tools, completely dismountable and dishwasher safe.
- Pulse function to coarse chopping.
- Delivered with: -5.8 qt stainless steel cutter bowl, transparent lid, scraper and microtoothed blade rotor.
- Capacity: -cutter mixer working capacity from 3.5 ounce (100 g) to 5.5 lbs (2.5 kg), for 50-100 meals per service.

## Construction

- Improved ventilation system to manage smoothly heavy duty use.
- Reinforced feet to withstand the repeated handling of the unit.
- All blades (available on request) are made in stainless steel and dishwasher safe.
- Food processing at 10 variable speeds: 300-3700 rpm.
- Power: TK55 - 1.3 HP.
- Stainless steel bowl has a high chimney to ensure high productivity also when processing liquids (75% of the nominal capacity).
- IPX5 (IP55) flat panel touch-control, waterproof panel.
- Compact and portable design.
- Asynchronous industrial motor with no brushes for high reliability and quiet functioning, stainless steel motor shaft.

## Included Accessories

- 1 of Lid and bowl scraper for 5.8 qts (5.5 L) cutter mixer PNC 650102
- 1 of Microtoothed blade rotor for 5.8 qts (5.5 L) PNC 653582 cutter mixer
- 1 of Stainless steel bowl for 5.8 qts (5.5 L) PNC 653590 cutter mixer

## Optional Accessories

- Lid and bowl scraper for 5.8 qts (5.5 L) cutter mixer PNC 650102
- EMULSIFYING KIT FOR K55 VARIABLE SPEED, INCLUDING 5.5QT SS BOWL, SMOOTH EMULSION PNC 650103
- Smooth blade rotor for 5.8 qts (5.5 L) cutter mixer PNC 653581
- Microtoothed blade rotor for 5.8 qts (5.5 L) cutter mixer PNC 653582
- Stainless steel bowl for 5.8 qts (5.5 L) cutter mixer PNC 653590

APPROVAL: \_\_\_\_\_



Food Processor/Cutter Mixer 5.8 QT - Variable Speed



# Food Processor Food Processor/Cutter Mixer 5.8 QT - Variable Speed

**Front**

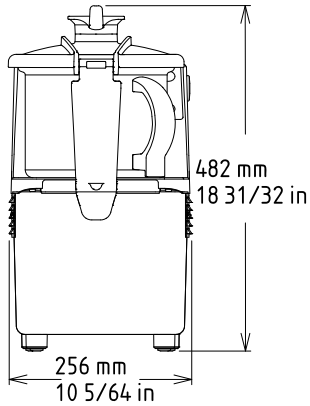

**Side**

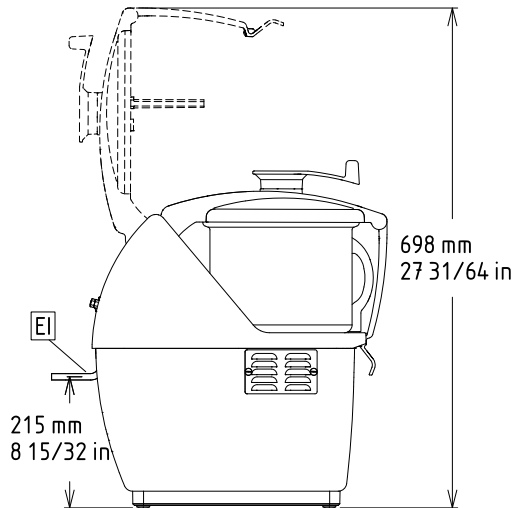

EI = Electrical connection

**Top**

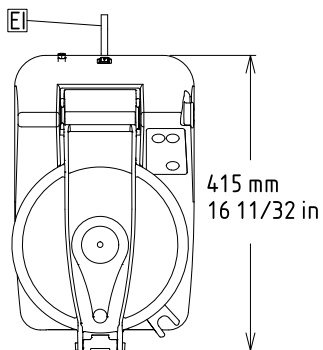

## Electric

Supply voltage:

600578 (DK55VVU) 110-120 V/1N ph/60 Hz

Electrical power, max:

1.3 kW

Total Watts:

1.3 kW

## Capacity:

Performance (up to):

2.5 - kg/Cycle

Capacity:

5.5 Litre

## Key Information:

External dimensions, Width: 256 mm

External dimensions, Height: 482 mm

External dimensions, Depth: 415 mm

Shipping weight: 23 kg

Food Processor  
Food Processor/Cutter Mixer 5.8 QT - Variable Speed

The company reserves the right to make modifications to the products without prior notice. All information correct at time of printing.

2020.01.30