



Electrolux
PROFESSIONAL

Modular Cooking Range Line 900XP Full Module Ambient Worktop with drawer

ITEM # _____

MODEL # _____

NAME # _____

SIS # _____

AIA # _____



Modular Cooking Range Line
900XP Full Module Ambient Worktop with drawer

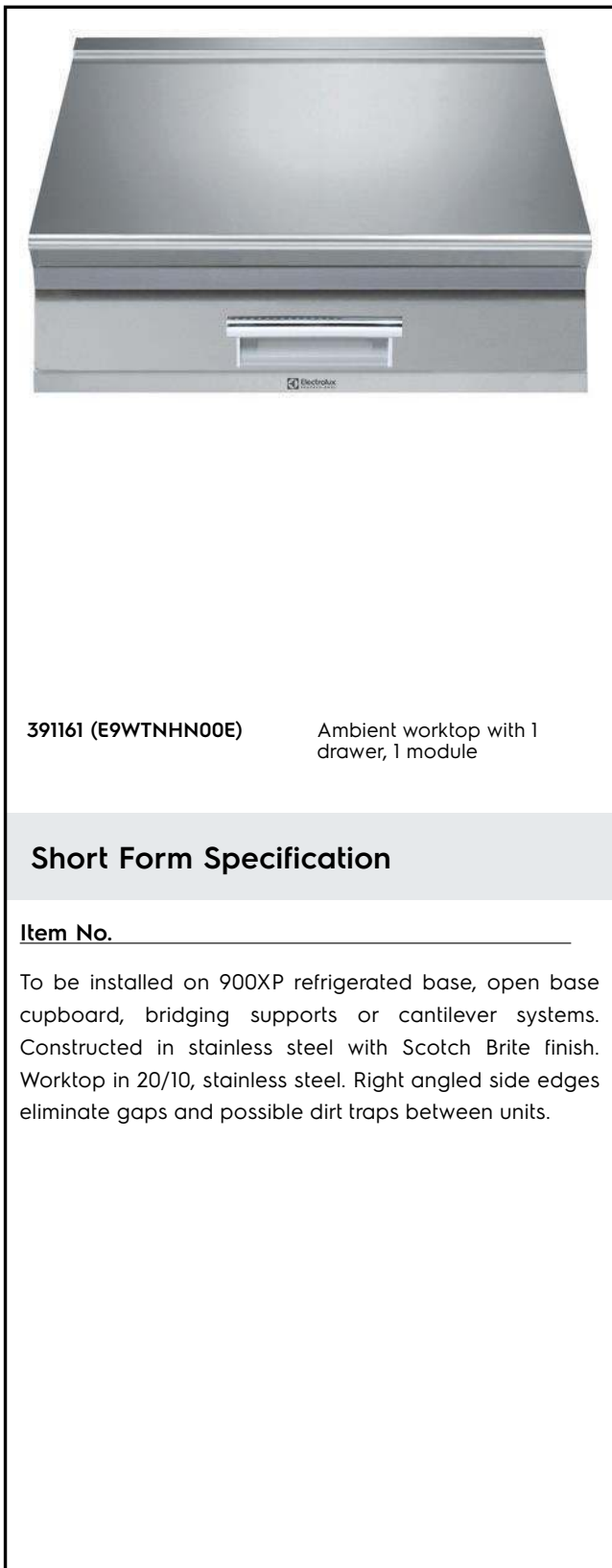

391161 (E9WTNHN00E)

Ambient worktop with 1
drawer, 1 module

Short Form Specification

Item No. _____

To be installed on 900XP refrigerated base, open base cupboard, bridging supports or cantilever systems. Constructed in stainless steel with Scotch Brite finish. Worktop in 20/10, stainless steel. Right angled side edges eliminate gaps and possible dirt traps between units.

APPROVAL: _____

Main Features

- Heavy duty internal frame in Stainless steel.
- Unit to be installed on other 900 line bases.
- Right angled side edges eliminate gaps and possible dirt traps between units.

Construction

- Stainless steel top provides a heavy duty work surface under any load.
- Unit is 930 mm deep to give a larger working surface area.



Experience the Excellence
www.electroluxprofessional.com

Optional Accessories

- Junction sealing kit PNC 206086
- Support for bridge type installation, 800mm PNC 206137
- Support for bridge type installation, 1000mm PNC 206138
- Support for bridge type installation, 1200mm PNC 206139
- Support for bridge type installation, 1400mm PNC 206140
- Support for bridge type installation, 1600mm PNC 206141
- Full module overshef PNC 206184
- Water column with swivel arm (water column extension not included) PNC 206289
- Water column extension for 900 line PNC 206290
- Back handrail 800mm, Marine PNC 206308
- Back handrail 1200mm, Marine PNC 206309
- Side handrail-right/left hand (900XP) PNC 216044
- Frontal handrail, 800mm PNC 216047
- Frontal handrail, 1200mm PNC 216049
- Frontal handrail, 1600mm PNC 216050
- Large handrail - portioning shelf, 800mm PNC 216186
- 2 side covering panels for top appliances PNC 216278

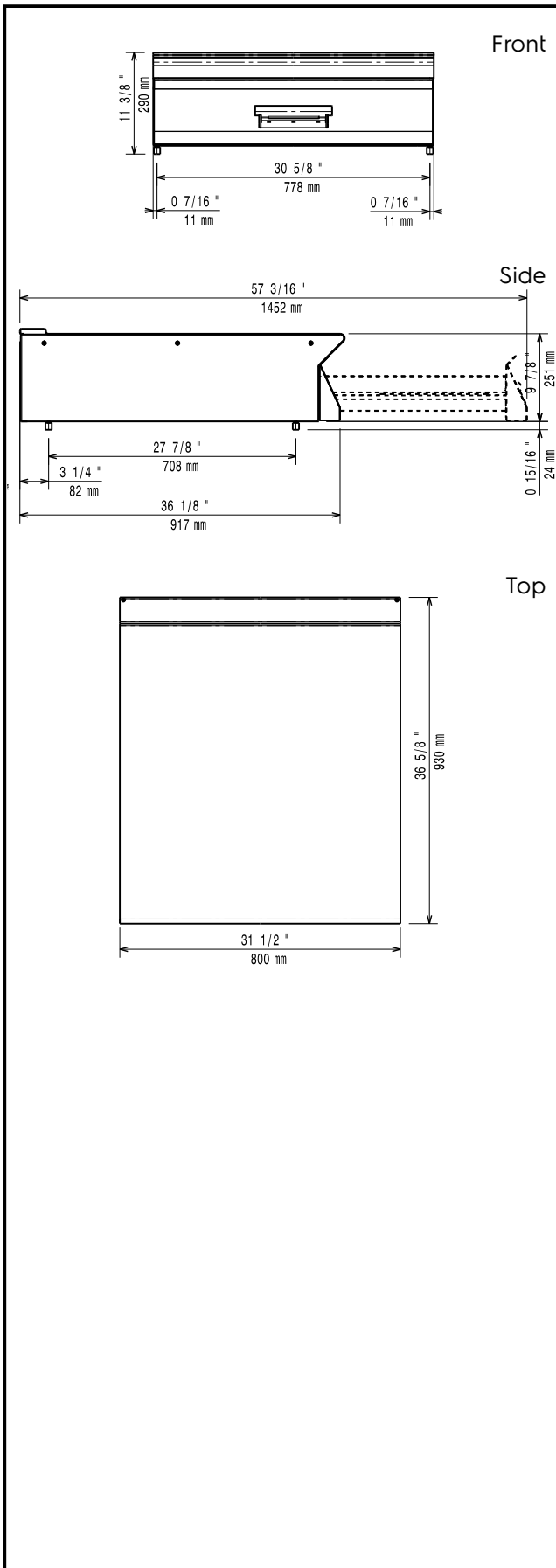

Key Information:

External dimensions, Width:	
391161 (E9WTNHN00E)	800 mm
External dimensions, Height:	250 mm
External dimensions, Depth:	930 mm
Net weight:	44 kg